

Superior Technology & High Quality

 ARIO TECHNO

Unattended Work Catcher & Storage Device

# SUPER ARIO Operator's Manual

---

Model No. SPA-500

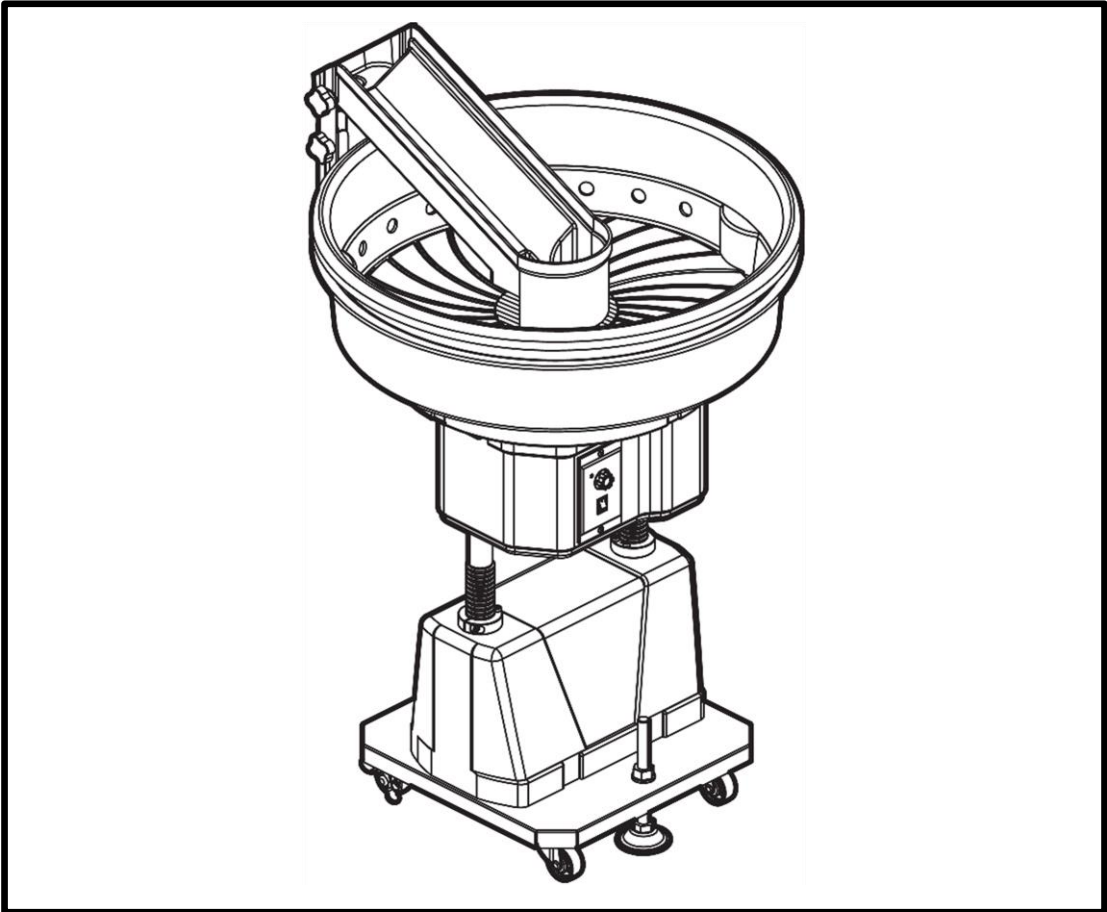

Warranty Card attached

**Thank you very much for your purchasing this Super Ario device.**

- Please read this Manual carefully and use device properly and safely.
- Please make sure to read [ Safety Cautions ](page2~4) before an operation.
- This Operator's Manual also serves as a Warranty Card. Please record the date of purchase and the seller's name, and keep in a safe place.



# Table of Contents

---

Firstly Please Make sure to read from here	Safety Instructions . . . . .	2~4
	Accompanied Parts . . . . .	5
How to Operate	(1) Assembling . . . . .	6~7
	(2) Parts Descriptions . . . . . And Usage	8~13
	(3) Maintenance and Cleaning	14
After Sales Service	(4) Technical . . . . . Specifications	15
	(5) Serviceable Parts . . . . .	15
	Warranty and . . . . . After Sales Service	16~17
	Warranty Card on the back cover	



---

# Safety Instruction



---

Before installing and operating this device, read this manual thoroughly. To protect operators from danger and risk as well as damages to the properties, important safety precautions are remarked as under.

■ A level of possible danger and hazard are indicated as below just in case of improper usage ignoring the precautions.

 <b>WARNING</b>	This symbol indicates very serious danger such as deadly or heavily injuries.
 <b>CAUTION</b>	This symbol indicates serious injuries or damages to properties.

■ Here are some examples of the symbols to be noted and be followed for the safe and proper operations of this device.

	Indicates “Do Not” ”Must Not” prohibited conducts.
	Indicates “Do it” ”Must Do it” compulsory instructions.

## **WARNING**



■ **STOP Operations Immediately in emergency and/or malfunctions.**

In such case it could cause smoke and/or fire. Immediately unplug an AC power cable and ask for repair services.

■ Please contact the dealer where you purchased this device for services.



No Disassembling

■ **DO NOT ATTEMPT To disassemble or repair, modify by yourself.**

It may cause fire, or cause abnormal running resulting in fire, electric shock, injuries.



No Fire

■ **Do Not Place this unit nearby the heater or any kind of device generating heat.**

Plastic parts might deform or melt causing fire.



■ **When moving and/or carrying the device, Do Not Pull the AC Power cable.**

It may cause the power cable short-circuited and/or snapped resulting in fire and electric shock.

# Safety Instructions

## WARNING



■ **Make sure to plug in the AC power cable to the wall outlet completely.**

Incomplete plugging may result in electric shock or fire.

● A damaged plug and/or a loose outlet must not be used.



■ **Do Not Step on the plastic tray and/or the aluminum bucket, or Do Not put stuff on them.**

It may cause falling and/or dropping of the stuff resulting in possible injuries.



No Water

■ **Do Not Expose this device to rain, water, or sprinkle, pour water over the device.**

It could cause short-circuit and fire, electric shock.



No Water

■ **No Wet Hand when Plugging or Unplugging AC Power cable.**

You could get electric shock.



■ **This device should be operated only from the type of power source indicated on the electrical rating label. No AC wall outlet nor cable, voltage out of the Range should be used.**

Overload usage by octopus-like legs-wiring may result in over heat and fire.

● Please refer to the Specifications of this device (page 14) for the rated power requirement.



■ **Do Not Pull the device by the AC power cable, nor plug in the wall outlet with the power cable fully stretched out.**

Too much tension on the AC power cable may result in short-circuit and/or snapping of the power cable and may cause fire or electric shock.

● If the AC power cord should be found in a bad condition, call for service by the dealer.



■ **Do Not Damage the AC Power cable nor Plug**

It may cause electric shock, short-circuit, fire.

● If the AC power cord should be found in a bad condition call for service by the dealer.



Unplug  
AC Power

■ **Make Sure to Unplug the device from AC Power Supply during maintenance service.**

If the device is still plugged in, it may active unexpectedly causing injuries and/or electric shock.

● If the AC power cord should be found in a bad condition, call for service by the dealer.



■ **Brush Dust off AC Power Cable periodically.**

Dust on the plug could cause insufficient insulation due to moisture resulting in fire.

● Unplug and clean with dry damp cloth.

● Unplug if the device is unused for long periods.

# Safety Instructions

## WARNING



### ■ When in Operation, Make Sure to Fix the device.

It is recommended to lock the caster and fix the device using the adjuster anchor bolt.



### ■ Do Not Place the device on an unstable place.

It may fall causing injury to an operator.  
Place on a stable flat floor.



### ■ Make Sure to engage Two (2) People when adjusting the height of the device.

If the height of Super Ario must be lowered or adjusted, loosen the screws of set collar to bring down the turn table.

But make sure this adjustment is made at least by two (2) operators, one to hold the turn table and the body, other one to loosen screws.

Do not pinch fingers between the dropping turn table body and the cover.



### ■ When Plugging or Unplugging, Make Sure to Hold by the Plug not by the cable.

It will prevent the power cable from short-circuit or snapping resulting in fire, electric shock.



### ■ Do Not Attempt to Hold or Press the Rotating Turn Table in operation.

When in operation, the turn table is turning round, and therefore it is quite dangerous trying to hold or stop the turn table by any reason.



### ■ Do Not Push/Pull by the Bucket nor the Tray

To move the device to the different location push/pull by the device main body and not by the bucket nor the tray.



### ■ No Abuse for Other Purposes.

Do not abuse this device for any other purpose than catching and storing the lathe works.

# Accompanied Parts (Unpacking Checklist)

When unpacking, please check accompanied parts and make sure if all the items are included in a good condition. If any item should be missing or in a bad condition, please contact your dealer.

Accompanied Parts with the device	Quantity check	Shooter Parts Itemized	Quantity check
-----------------------------------	----------------	------------------------	----------------

① Device Main Body	1pc.	<input type="checkbox"/>	
--------------------	------	--------------------------	--

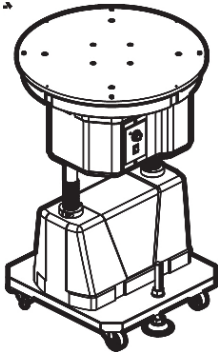

② Aluminum Bucket	1pc.	<input type="checkbox"/>	
-------------------	------	--------------------------	--

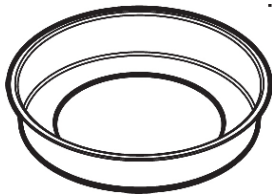

③ Plastic Tray	1pc.	<input type="checkbox"/>	
----------------	------	--------------------------	--

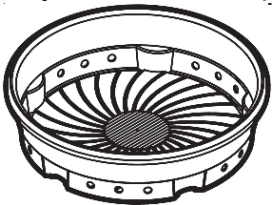

④ Oil Recycling Drain Hose	1pc.	<input type="checkbox"/>	
----------------------------	------	--------------------------	--



⑤ Operator's Manual	1pc.	<input type="checkbox"/>	
---------------------	------	--------------------------	--

⑥ Shooter	1pc.	<input type="checkbox"/>	
-----------	------	--------------------------	--

⑦ Slide Base	1pc.	<input type="checkbox"/>	
--------------	------	--------------------------	--

⑧ Shooter Slide	1pc.	<input type="checkbox"/>	
-----------------	------	--------------------------	--

⑨ Shooter Locking Bracket	1pc.	<input type="checkbox"/>	
---------------------------	------	--------------------------	--

⑩ Flat Knob Screw	6pc.	<input type="checkbox"/>	
-------------------	------	--------------------------	--

⑪ Nut	2pc.	<input type="checkbox"/>	
-------	------	--------------------------	--

⑫ Washer	8pc.	<input type="checkbox"/>	
----------	------	--------------------------	--

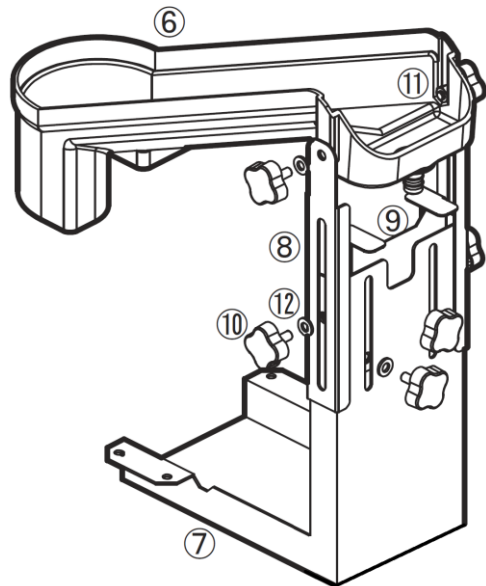

⑬ Hex Screw	4pc.	<input type="checkbox"/>	
-------------	------	--------------------------	--



⑭ Hex Wrench	1pc.	<input type="checkbox"/>	
--------------	------	--------------------------	--



# Assembling

## Mounting the Shooter

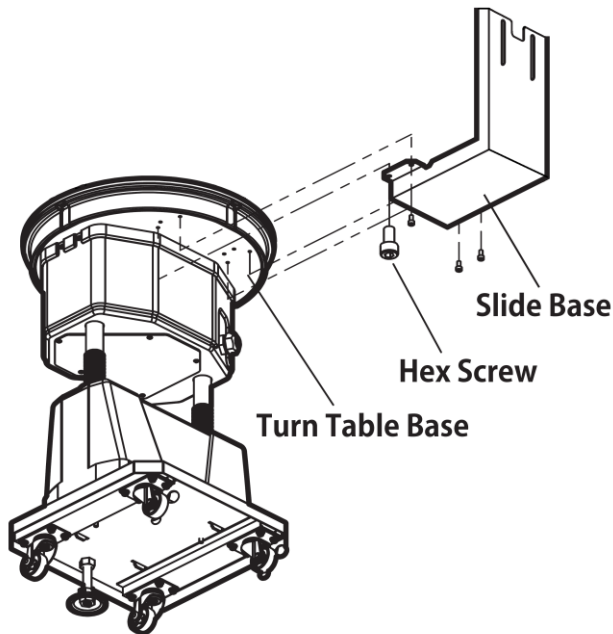

① Apply the slide base underneath the turn table, try to align with screw holes, and using 4 screws fix the slide base to the main body.

(See Fig. Left)

② Set the nuts inside of the shooter, by matching with 2 holes (left & right).

(See Fig. Below)

③ Place the shooter in-between the shooter slide insert the washer, align with the nuts, and tighten with flat knob screws.

④ Align and mount the shooter locking bracket along the long slots on the slide base using the flat knob screws and the washers.

(See Fig. Right)

⑤ Put in the assembled shooter slide as in ③ into the slide base as in ④, and tighten with the flat knob and washers from both sides.

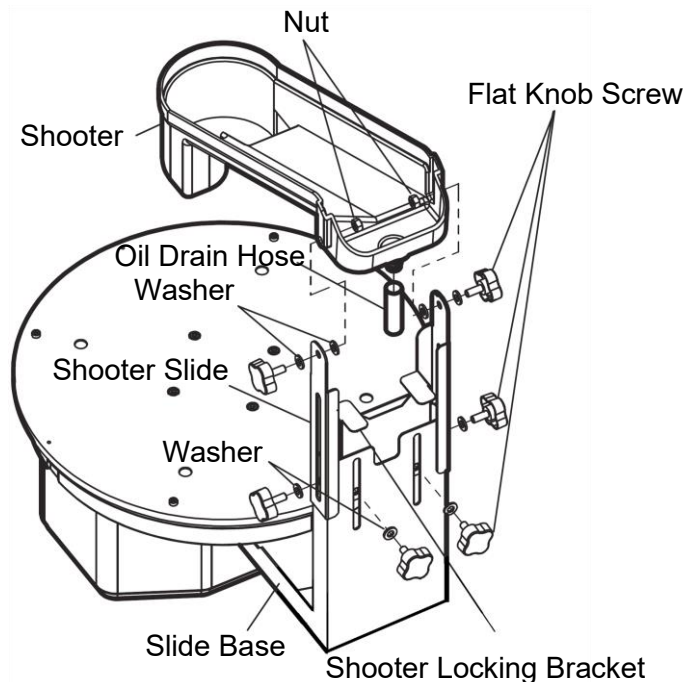



# Assembling

## Setting the Bucket and Shooter

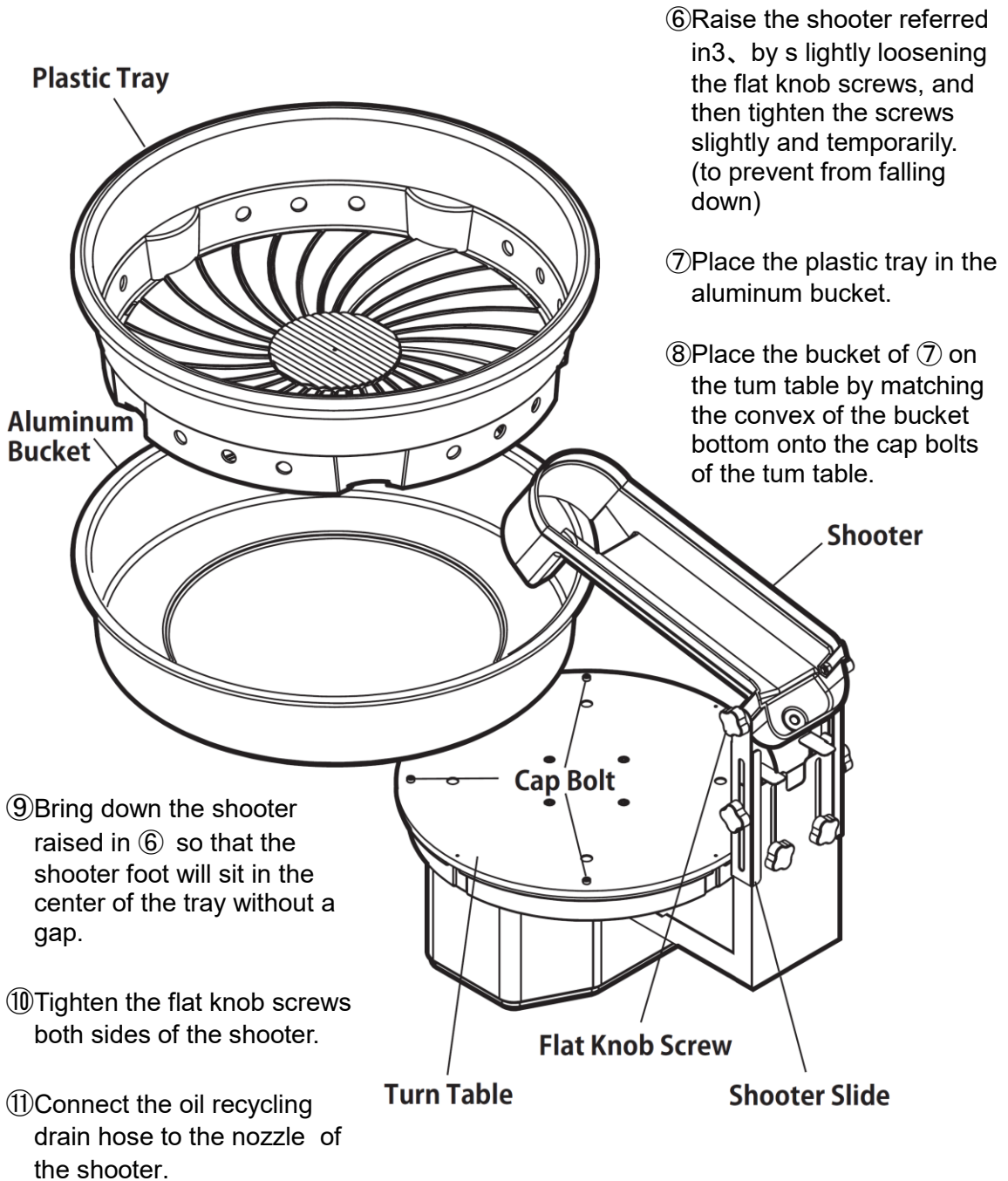

# Part Names and Functions

## Part Names

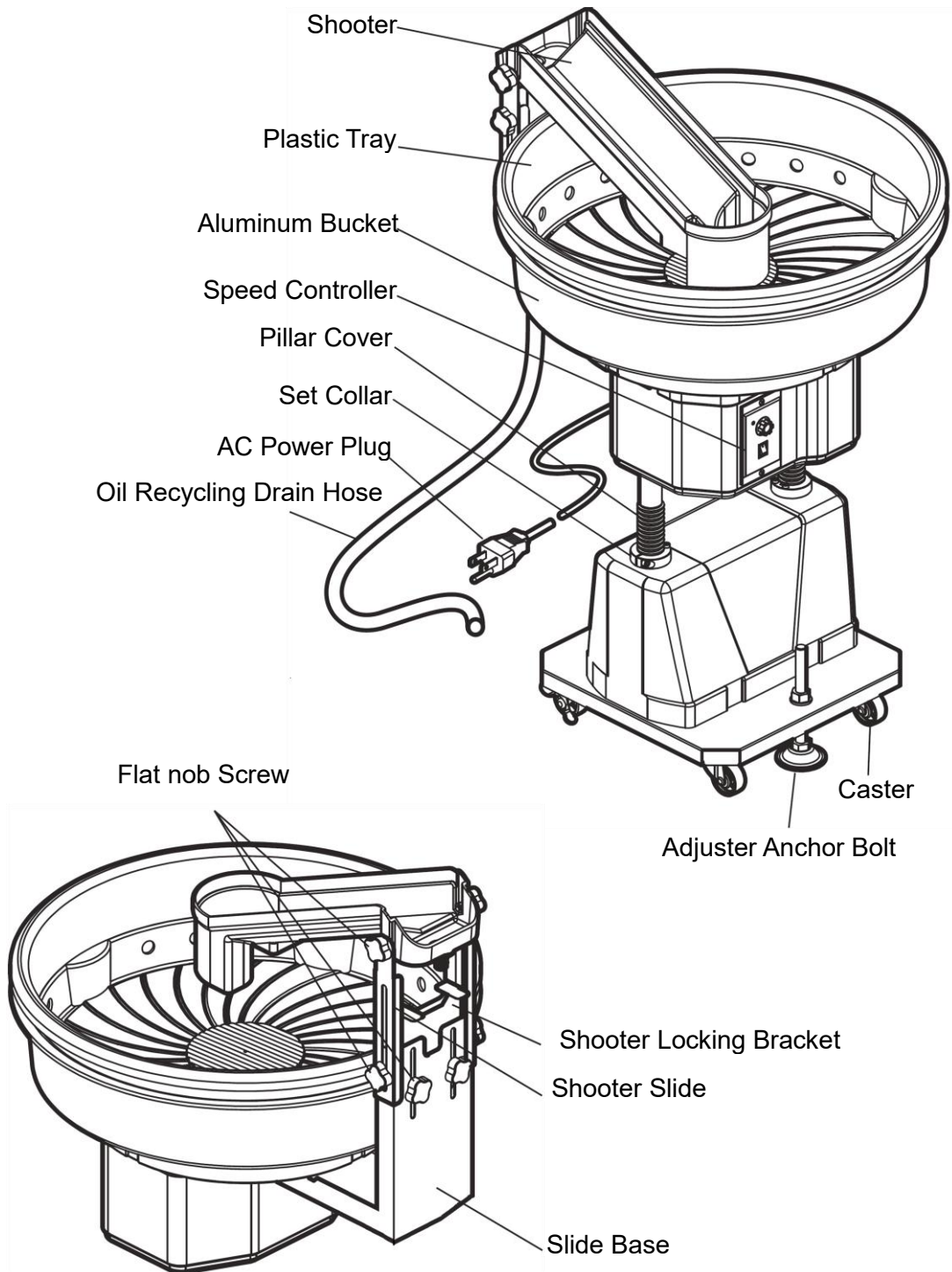

# Part Names and Functions

## Moving the Device

- ① Unplug the AC power cable.
- ② Remove the bucket and the tray.  
(if necessary raise the shooter)
- ③ Unscrew the adjuster bolt so that the bolt will come off from the floor.
- ④ Unlock the casters (2pcs)
- ⑤ Push or pull by the device main body.

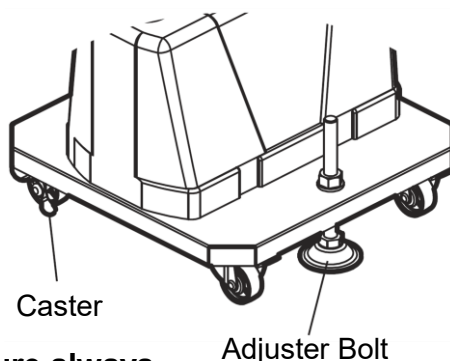

■ **When moving the device, make sure always to hold tile main body, and not by the shooter nor the AC power cable or else.**

## Adjusting the Height of the Device



■ **Make Sure to Engage Two (2) + Operators to do this right.**

When adjusting the height of the device, please allocate at least two (2) operators for safety reason, one to hold the device and the other to loosen/tighten the screws.

- ① Slowly loosen the cap bolt (2pcs, left & right) on the set collar using the hex wrench (4mm) provided, and bring down the tum table body. Make sure to hold firmly the tum table body so that it will not fall down rapidly.
- ② Place the aluminum bucket and Plastic Tray.
- ③ Place the shooter.
- ④ Adjust the height so that the shooter top end will fit right underneath the lathe machine's conveyor belt work exit. (the smaller difference is, less jumping of the works.)
- ⑤ As the best height is reached, tighten the cap screws to fix the device height.

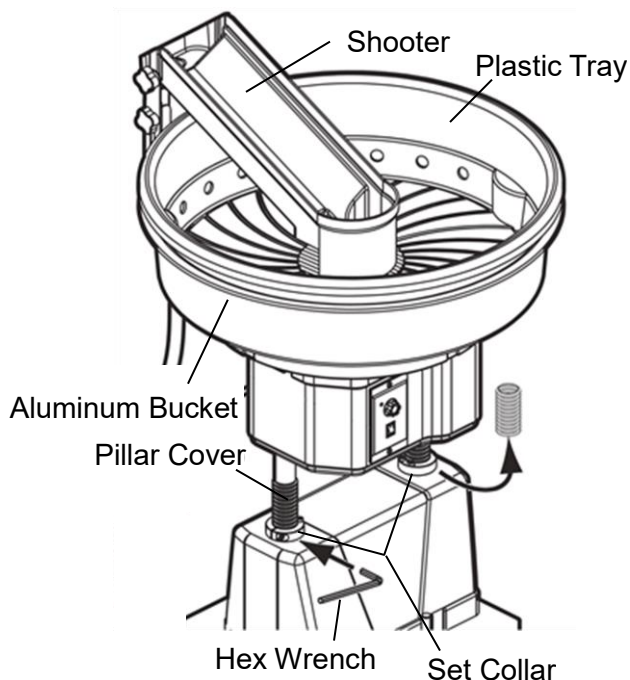

### Note:

- Make sure to tighten the cap screws surely.
- Remove the shaft cover when adjusting to the lowest height.

# Part Names and Functions

## Adjusting the Height of the Shooter

- ① Loosen all the flat knob screws (6pcs.) to set all the parts free and loose.
- ② Place the shooter foot in the center of the tray. (refer to page11)
- ③ While maintaining the shooter position in ②, tighten the flat knob screws at both sides of the shooter slide, and fix the angle of the shooter and the height of the shooter slide.
- ④ Push up the shooter locking bracket until it contacts to the bottom of the shooter and tighten the flat knob screws.
- ⑤ To take up the bucket (and/or the tray), loosen the flat knob screws (2pcs.) at the bottom of the shooter slide, lift up the shooter slide avoiding an interference of the bucket (and/or the tray) and the shooter, hold and fix the shooter slide, and take up the bucket (and/or the tray).
- ⑥ To place the bucket on the turn table, loosen the flat knob screws (2pcs.) at the bottom of the shooter slide, and push down the shooter slide until the shooter's bottom end touches the shooter locking bracket, then tighten the flat knob screws and fix.

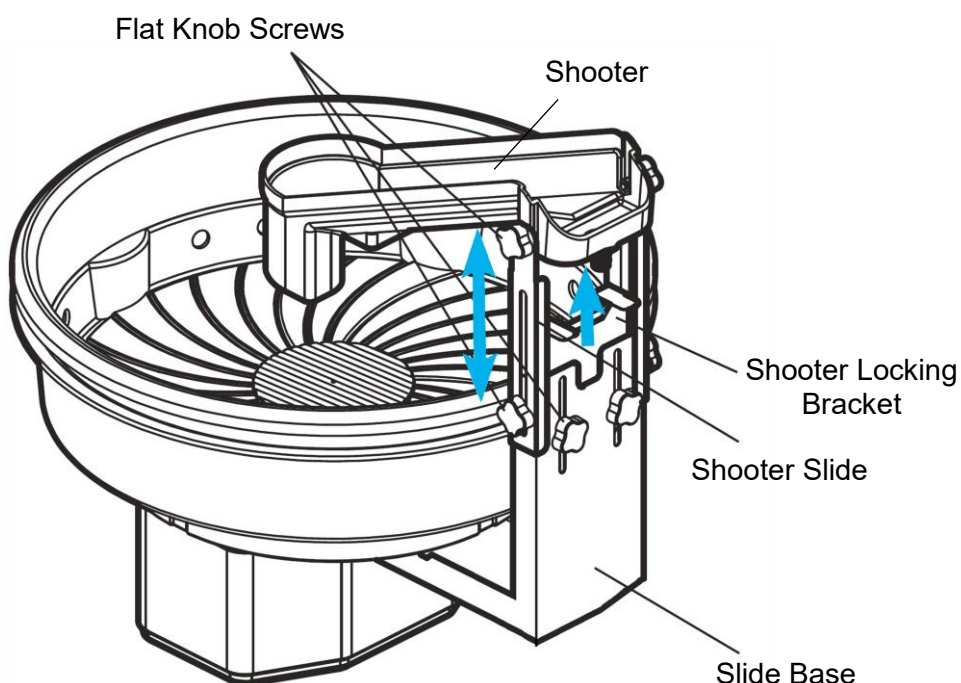

# Part Names and Functions

## Adjusting the Height of the Shooter

- ① Set the shooter position so that the shooter foot will sit on the center of the plastic tray leaving no gap in between, and then tighten the flat knob screws.
- ② Adjust and determine the position of the device by moving the device little by little forward/backward and/or left/right so that the shooter top end comes right underneath the work e ｷ—it of the lathe machine conveyor. (Also make sure the oil drop catcher is positioned properly to receive the oil drops running out of the lathe conveyor belt.)
- ③ Lock the casters (2pcs.)
- ④ Tighten the adjuster (anchor) bolt and stabilize the device positioning.

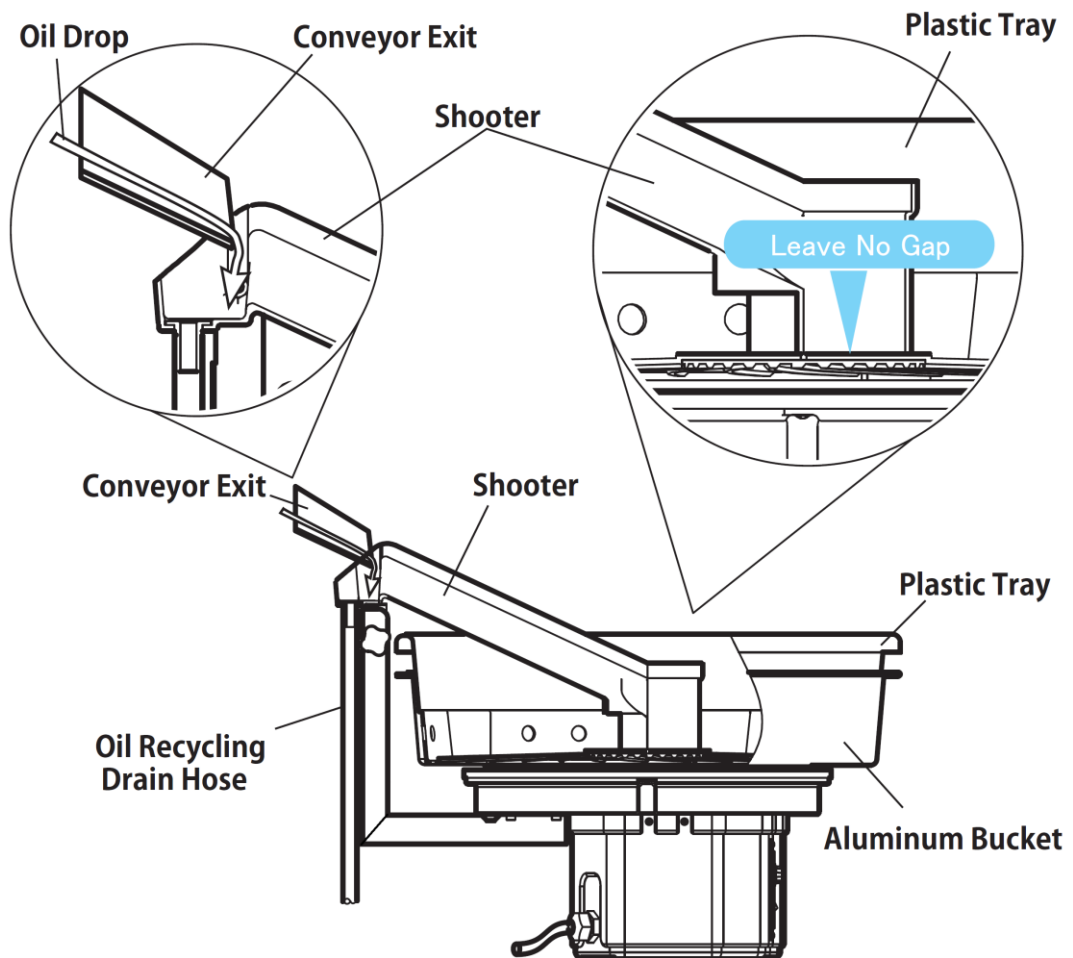

# Part Names and Functions

## Operations

- ① Plug in the AC power cable to the wall outlet. The green LED lamp of the speed controller will turn on.
- ② Push Start Switch ON. (The turn table starts to turn round at the speed set by the speed controller factory default position.)
- ③ Turn the speed controller's volume knob to adjust for the desired speed. (The speed range is 0.3~4.6rpm/50Hz, or 0.3~5.5rpm/60Hz)

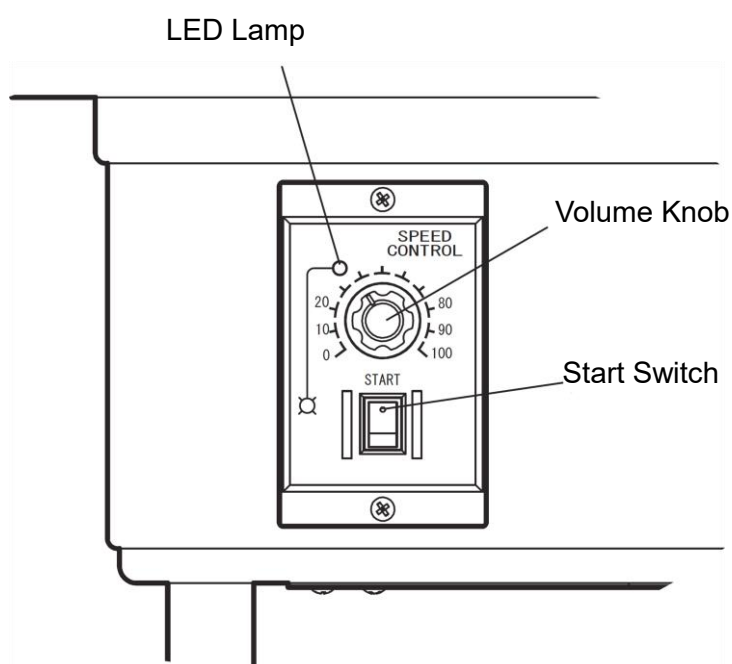

■ **Make Sure to Stabilize the Device before Operations.**



■ **Do Not Attempt to Hold or Press the Turn Table in operations.**

### Note:

- Make sure there is no interfering objects to the bucket, tray, turn table.
- Turn off the Start Switch and Unplug the AC Power Cable if the device is not going to be used for a long period.

# Part Names and Functions

## Using Rinsing Liquid

- ① Make sure the plastic tray is placed in the aluminum bucket, before filling out the rinsing liquid.

### Note:

- The material of the plastic tray and the shooter is acryl denatured high impact type PVC, which is quite endurable to most rinsing liquid but there might be some rinsing liquid that may cause deterioration and/or deformation.
- ② Proper amount of the rinsing liquid is to the level in where the works stored in the tray is completely steeped. General guide level is up to a little less than the half depth of the tray (about 7lit.) (Please note that as the works get stored more, the higher the liquid level becomes. Be careful of overflow of the liquid.
  - ③ To take up the tray, loosen the flat knob screws both sides of the shooter, and raise up the shooter to make a way for the tray.
  - ④ Slowly and horizontally pick up the tray. Do not spill the rinsing liquid.

### Note:

- Do not hurry picking up the tray too quickly as it might cause the rinsing liquid spill from the tray and/or the bucket. Slowly and up straight pick up the tray, allowing some time so that the liquid will flow out through the holes in the tray to the bucket.
- ⑤ Collect the works and empty the tray, and put it again in the bucket.

### Note:

- When putting back the tray in the bucket wherein the rinsing liquid is filled out, put it down slowly allowing some time so that the liquid will flow into the tray through the holes gradually. Too quick placement may cause the liquid spill out from the bucket.

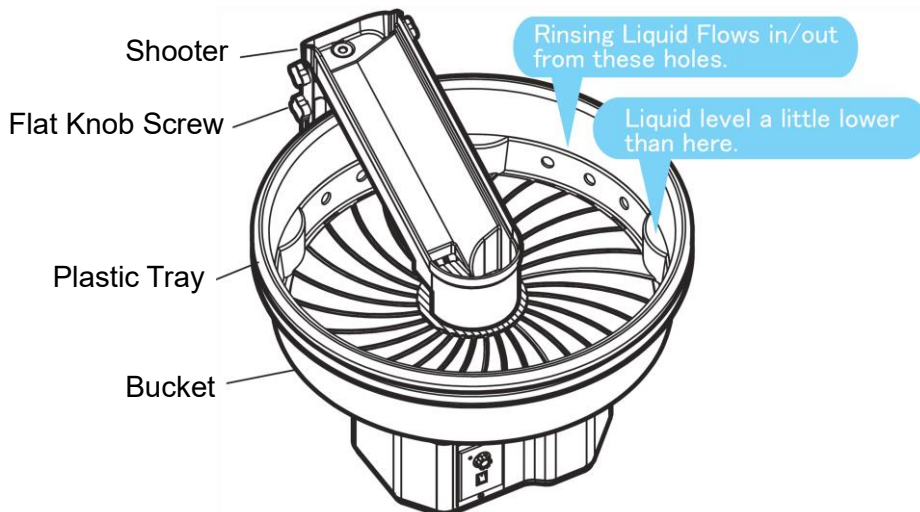

## (3) Maintenance and Cleaning

---

### Maintenance and Cleaning Steps

- ① Unplug the AC Power Cable from the wall outlet.
- ② Remove the bucket.
- ③ Dip a soft cloth in lukewarm water or thinned kitchen cleanser, and wring it strongly, and wipe dirt, stains off.

#### Note:

● Do not rub or wipe with a dry cloth, nor use benzene, paint thinner, cleanser, alkaline detergent. They may cause a scratch on the surface and/or cause deterioration, discoloration.



■ **When unplugging the AC Power Cable,  
Never yank by the cable but pull out by the AC plug.**



## (4) Technical Specifications

---

Power Source	Single-phase AC 200~220V 50/60Hz 25W
Aluminum Bucket & Plastic Tray	Φ500
Rotation Speed	0.3~4.6rpm/50Hz, 0.3~5.5rpm/60Hz
Height (Floor to Shooter Top)	Adjustable 650~750 mm (Standard model SPA-500) Adjustable 750~850 mm (High model SPA-500H)
Storable Max Weight	25 kg (including rising liquid about 7 kg)
Work Size Applicable	Φ4mm~25mm L.75mm Max
Dimensions	φ500 X Height 650~750 mm (Standard model SPA-500) φ500 X Height 750~850 mm (High model SPA-500H) (both excluding protrusions)
Weight	20.3 kg (Standard model SPA-500) 21.0 kg (High model SPA-500H)

Note : Products 'Technical Specifications and appearance are subject to change due to improvement without advanced notifications.

## (5) Serviceable Parts

---

Part Name	Part No.
Aluminum Bucket φ500	B0014-06-001
Plastic Tray Φ500	B0014-06-013
Shooter	B0014-00-023
Plastic Tray Φ500 with a 3-stage mounted	B0014-16-000

## Limited Warranty and After Sales Service

---

If you should have any question regarding operations, repair, and maintenance, etc., please contact your dealer where you purchased this product.

### Limited Warranty Card

- Warranty Card is attached in the back cover of this manual.
- Please write the date of purchase, the dealer name, etc. and read thoroughly, keep it in a safe place.
- The Warranty period is one year from the date of purchase.

### Service Parts Availability Period

- Service parts for maintenance and/or repair of this product will be available for seven (7) years from the date of this product discontinuation at the manufacturer.
- Service parts mean the parts that are necessary to repair/maintain this product's performance and quality.

### When Service is required

- If the device is out of order, firstly unplug the AC power cable, and contact your dealer.
- If within the warranty period, according to the warranty, your dealer will assist you. Please show the warranty card to your dealer for repair services.
- If out of the warranty period, please contact your dealer.

Your dealer will examine the condition of the device and if a dealer should judge your device is repairable, he/she will advise you to repair and present you an estimate of repair cost.

- Repair cost will include engineering fees, parts cost, and travel fee of a dealer repair engineer (s) .

# Limited Warranty and After Sales Service

---

## Limited Warranty Conditions

This warranty is valid only for Super Ario Work Catcher and Storage Device purchased in the United States from Authorized dealers. This warranty applies only to the original purchaser. The original dated bill of sale, sales slip or proof of purchase must be submitted to an authorized dealer at the time warranty service is requested.

1. If you wish to repair the device under a warranty, please show this warranty card to your dealer along with the above-mentioned documents, otherwise repair charge will incur.
2. If the warranty card does not have written record required, or should show unauthorized changes of articles, it becomes invalid.
3. The following incidents will incur you repair charges even within the warranty period;
  - a. The damages and/or faults resulting from improper use, abuse, misuse, changes, disassembly by operators.
  - b. The damages and/or faults resulting from dropping or falling by operators.
  - c. The damages and/or faults resulting from fires, salt, gas, floods, earthquakes and other acts of God.
  - d. The damages and/or faults resulting from incorrect power line voltage.
  - e. Normal wear and tear.
  - f. No showing of this warranty card.
4. This Warranty Card will not be re-issued. Please keep in a safe place.
5. Freight charges and other expenses for repair of the device within a warranty period:

A purchaser will bear the expenses when sending from the purchaser to a dealer.

After repair, a dealer will bear the expenses for the return.

In case of charged repairs out of a warranty period, or charged repairs even within a warranty period, a purchaser will bear the expenses both ways.
6. The Manufacturer (Ario Techno) does not assume any obligation or liability for any losses or damages, direct or indirect, by the usage of this product.
7. For any other question, please contact your dealer.

Please show this Warranty Card to your dealer when repair services are required, and otherwise please keep this Warranty Card in a safe place.

※please make sure to fill in the following items, otherwise this warranty card will not be valid.

## LIMITED WARRANTY CARD

### For Super Ario Work Catcher and Storage Device

Model No.	SPA—5 0 0	Serial No.
Purchaser Information : Name		
Business Address : (Zip Code)		
Phone No.		
Warranty Period : One (1) Year	Date of Purchase : (Y-M-D)	
Dealer Name and Address;		
Dealer Phone No.		

The Manufacturer (Ario Techno) certifies this product has been manufactured under our quality assurance control and has passed our inspection test, and warrants this product against defects in materials and workmanship for a period of One (1) year.

In case of fault, trouble and error even if a purchaser has been using this device properly in a normal condition following this Operator's Manual and all the cautions and warnings been observed, please contact your dealer showing this warranty card and your dealer will repair, and/or adjust the device free of charge under warranty (one year from the date of purchase).

Please note the Warranty Conditions in a previous page to be eligible for warranty repair services.

Manufacturer : ARIO TECHNICO CO.,LTD.



Head Office : 10-145, Minami-Hatsushima-Cho Amagasaki City  
Hyogo Pref. 660-0833 Japan

Tel : +81-6-4868-5001 Fax : +81-6-4868-5010

South Plant : 10-118, Minami-Hatsushima-Cho Amagasaki City  
Hyogo Pref. 660-0833 Japan

Tel : +81-6-6488-5550 Fax : +81-6-6488-5540

URL : <http://www.ario.co.jp> E-Mail : [info@ario.co.jp](mailto:info@ario.co.jp)

Printed ID : 20190510